

Schraubzwinde, stark

706



Produkteigenschaften

- Material: Premium Flex Plus Kohlenstoffstahl
- gehärtet und vergütet
- Ergonomisch geformter Holzgriff, lackiert



Vorteile:

- integrierte Bremse verhindert unkontrolliertes Abrutschen des Gleitbügels
- maximale Spannkraft 6000N
- Gleitbügel gezahnt
- Druckplatte beweglich

Verwendung:

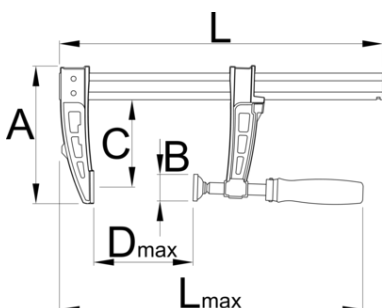
- für Tischler-, Schweiß- und Montagearbeiten



		$D\uparrow$	L	$L\uparrow$	A	C	B	
626283	200	200	323	465	181	136	34	1750
626284	300	300	423	565	181	136	34	1870
626285	400	400	523	665	181	136	34	2090
626286	500	500	623	765	181	136	34	2310
626287	600	600	723	865	181	136	34	2530
626288	1000	1000	1123	1265	181	136	34	3410

* Bilder von Produkten sind Symbolfotos. Abmessungen sind in mm, Gewichte in Gramm.

Verwendung (Bilder)



Mehrstufig
einstellbare
Gleitbacke

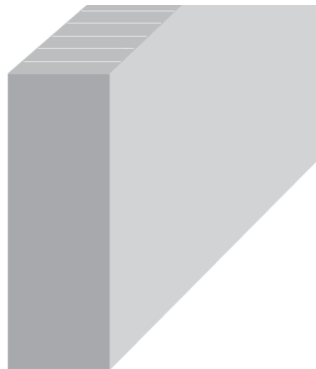

Schiene
Rechteckprofil aus
hochfestem Stahl,
kalibriert, gezahnt.
Backen lackiert,
Schiene verzinkt.



Schraube mit
Trapezgewinde: Mehr
Klemmkraft bei
weniger
Betätigungskraft.



Schwenkfuß



