

# Стабилен пневматски одвртувач

1563



## Profiles



## Product features

- 8000 в/мин во слободен од
- макс. вртежен момент 745 Nm
- препорачан воздушен притисок: 6, 2 бар

- потрошувачка на воздух 164 l / min
- Приклучок за внес на воздух 1/4"
- ниво на бучава 104dB (A)
- максимална големина на завртки M20

### Предности:

- композитно моторно куќиште
- се справи со издувните гасови (придушувач)
- една рака напред / назад
- компактен и моќен
- Џамбо чекан механизам



### Употреба:

- автомобилска индустрија
- Авио индустрија
- опрема за земјоделие
- тешка индустрија
- поголема градежна машина
- индустрија за бродоградба
- индивидуална монтажа

### Важно!

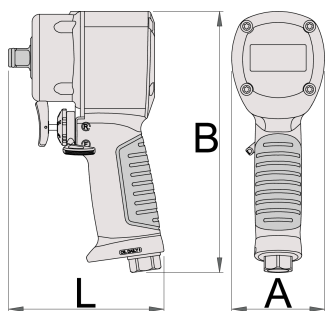
- Секогаш користете Униор ИМПАСТ насадни клучеви



		<b>L</b>	<b>A</b>	<b>B</b>		
627568	1/2"	105,4	63	177	745	1329

\* Сликите на производите се симболични. Сите димензии се во мм, тежината е во грамови. Сите наведени димензии може да се разликуваат во ниво на толеранција

## Usage (pictures)



## Photo (pictures)



## Accessories



Спојка, машки дел



Спојка, машки дел



Спојка, женски дел



Спојка, женски дел



Регулатор за пневматски филтер и подмачкувач 3/8"



Припремна група 1/2"



Спирално црево за воздух

## Safety tips



- The pressure in the tool during the operation has to be at least 6.2 bar for the tool to work properly.
- Regularly clean and dry the air filters and inlet air supply.
- Always use clean and dry air with the correct mixture of oil, for maximum tool life.
- Check the joints and ensure that the tubes and other equipment are not damaged before use.
- All tools should be gently oiled prior to being stored.
- Always store pneumatic tools in dry places away from water.
- Always use original spare parts.
- Repairs can be performed only by authorised staff people authorised by Unior d.d.
- Always disconnect tools not in use from the air supply.