

Kompakt pneumatikus ütvecsavarozó

1563



Profilok



Termékjellemzők

- üresjárat sebesség: 8000 f/min

- max. nyomaték: 745 Nm
- ajánlott üzemi nyomás: 6,2 bar
- levegőfelhasználás: 164 l/min
- levegőcsatlakozás: 1/4"
- zajszint: 104 dB(A)
- max. csavarméret: M20

Előnyök:

- kompozit motorburkolat
- levegőkiáramlás a markolatnál (hangfogó)
- hajtásirány egy kézzel váltható
- kompakt és erőteljes
- nagyméretű kalapácsos mechanizmus





Használat:

- autóipar
- repülőgépipar
- mezőgazdasági gépek, eszközök
- nehézipar
- nagyméretű építőipari gépek
- hajóépítő ipar
- egyedi összeszerelés

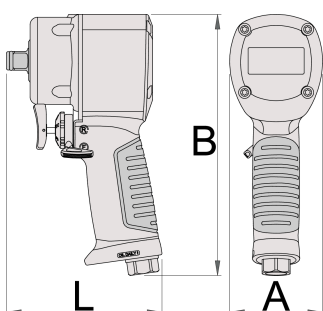
Fontos!

- Minden esetben használjunk Unior gépi dugókulcsokat.



						
627568	1/2"	105,4	63	177	745	1329

* A termékeképek illusztrációk. Minden feltüntetett méret milliméterben, a tömegek grammokban. Az összes feltüntetett méret eltérhet a toleranciának megfelelően.

Használat (pictures)



Photo (pictures)



Accessories



Gyorscsatlakozó



Gyorscsatlakozó



Gyorscsatlakozó hüvely



Gyorscsatlakozó hüvely



Levegőelőkészítő, 3/8"



Levegőelőkészítő, 1/2"



Spiráltömlő

Safety tips



- The pressure in the tool during the operation has to be at least 6.2 bar for the tool to work properly.
- Regularly clean and dry the air filters and inlet air supply.
- Always use clean and dry air with the correct mixture of oil, for maximum tool life.
- Check the joints and ensure that the tubes and other equipment are not damaged before use.
- All tools should be gently oiled prior to being stored.
- Always store pneumatic tools in dry places away from water.
- Always use original spare parts.
- Repairs can be performed only by authorised staff people authorised by Unior d.d.
- Always disconnect tools not in use from the air supply.