

Izvijač pneumatski mini, prihvatač 1/2"

1563



Profili



Atributi proizvoda

- 8.000 o/min u slobodnom hod

- Max. okretni momenat 745 Nm
- Preporučeni radni tlak: 6, 2 bara
- Uporaba zraka 164 l/min
- Priključak za zrak: 1/4"
- Nivo buke 104dB (A)
- za vijke do M20

Prednosti:

- Kompozitno kućište motora
- U ručku ugrađen prigušivač buke
- Jednoručna izmjena smjera rada
- Kompaktan i moćan
- Udarni mehanizam JUMBO čekić



Upotreba

- Automobilska industrija
- Avionska industrija
- Poljoprivredna mehanizacija
- Teška industrija
- Veći građevinski strojevi
- Brodogradnja
- Individualna montaža

Važno!

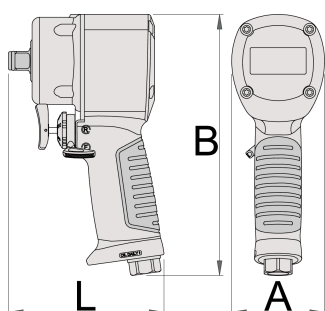
- UVIJEK koristite Uniorove IMPACT nasadne ključeve i pribor



		L	A	B		
627568	1/2"	105,4	63	177	745	1329

* Slike proizvoda su simbolične. Sve dimenzije su u mm, masa je u g.

upotreba (pictures)



Photo (pictures)



Accessories



Spojnica muška



Spojnica muška



Spojnica ženska



Spojnica ženska



Pripremna grupa 3/8"



Pripremna grupa 1/2"



Cijev spiralna za zrak

Safety tips



- The pressure in the tool during the operation has to be at least 6.2 bar for the tool to work properly.
- Regularly clean and dry the air filters and inlet air supply.
- Always use clean and dry air with the correct mixture of oil, for maximum tool life.
- Check the joints and ensure that the tubes and other equipment are not damaged before use.
- All tools should be gently oiled prior to being stored.
- Always store pneumatic tools in dry places away from water.
- Always use original spare parts.
- Repairs can be performed only by authorised staff people authorised by Unior d.d.
- Always disconnect tools not in use from the air supply.