

# Clé à chocs 1/2"

1563



## Profils



## Description produit

- Vitesse : 8000tr/min
- Couple max. 745 Nm
- Pression d'air recommandée : 6, 2 bar

- Consommation d'air 164 l/min
- Entrée d'air : 1/4"
- Niveau sonore 104dB(A)
- Dimension de boulon : maxi M20

### Avantages :

- Boitier du moteur en composite
- Poignée d'échappement (silencieux)
- Changement de sens d'une main
- Compact et puissant
- Mécanisme de gros marteau

### Utilisation:

- Industrie Automobile
- Industrie aéronautique
- Industrie agricole
- Industrie lourde
- Construction de machines
- Industrie navale
- Montage répétitif

### Important !

- Toujours utiliser des douilles à chocs UNIOR

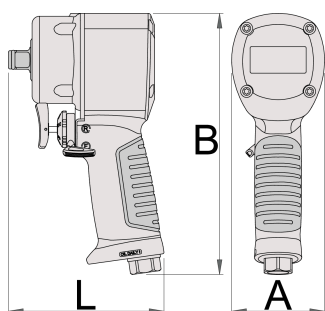

		<b>L</b>	<b>A</b>	<b>B</b>		
627568	1/2"	105,4	63	177	745	1329

\* Les images des produits ne sont pas contractuelles. Toutes les dimensions sont en mm, les poids en grammes.

## Utilisation (pictures)



## Photo (pictures)



## Accessories



Embout fileté



Embout fileté



Raccord rapide fileté



Raccord rapide fileté



Régulateur, épurateur, lubrificateur 3/8"



Régulateur, épurateur, lubrificateur 1/2"



Tuyau pneumatique spiralé

## Safety tips



- The pressure in the tool during the operation has to be at least 6.2 bar for the tool to work properly.
- Regularly clean and dry the air filters and inlet air supply.
- Always use clean and dry air with the correct mixture of oil, for maximum tool life.
- Check the joints and ensure that the tubes and other equipment are not damaged before use.
- All tools should be gently oiled prior to being stored.
- Always store pneumatic tools in dry places away from water.
- Always use original spare parts.
- Repairs can be performed only by authorised staff people authorised by Unior d.d.
- Always disconnect tools not in use from the air supply.