

Pistolet pneumatike

1563



Profiles



Product features

- Shpejtësia pa pagesë 8000 revolucion në minuta
- maksimumi çift rrotullues: 745 Nm
- Presioni i rekomanduar i furnizimit me ajër: 6.2 bar

- Konsumi i ajrit të kompresuar: 164 l/min
- gji ajrit 1/4 "
- Niveli i zhurmës: 104dB(A)
- për vida deri në M20

Avantazhet:

- strehim i përbërë
- me shter në dorezë për funksionim më të qetë
- ndryshim i lehtë dhe i shpejtë i drejtimit me një rën dorë
- kompakte dhe e fortë
- mekanizmi i një ndikimi të vetëm JUMBO



Përdorim:

- industria e makinave
- industria avion
- pajisje bujqësore
- industria e rëndë
- makineri më të mëdha të ndërtimit
- industria e ndërtimit të anijeve
- montimi individuale

E rëndësishme!

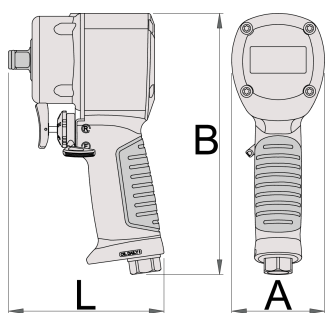
- Gjithmonë përdorni UNIOR ndikim bazat.



		L	A	B		
627568	1/2"	105,4	63	177	745	1329

* Imazhet e produkteve janë simbolike. Të gjitha dimensionet janë në mm, pesha në gram. Të gjitha dimensionet e listuara mund të ndryshojnë në tolerancë.

Usage (pictures)



Photo (pictures)



Accessories



Lidhëse mashkullore



Lidhëse mashkullore



Lidhëse femore



Lidhëse femore



Rregullatori pneumatik i filtrit dhe lubrifikuesi 3/8"



Rregullatori pneumatik i filtrit dhe lubrifikuesi 1/2"



Gyp I ajrit spiral

Safety tips



- The pressure in the tool during the operation has to be at least 6.2 bar for the tool to work properly.
- Regularly clean and dry the air filters and inlet air supply.
- Always use clean and dry air with the correct mixture of oil, for maximum tool life.
- Check the joints and ensure that the tubes and other equipment are not damaged before use.
- All tools should be gently oiled prior to being stored.
- Always store pneumatic tools in dry places away from water.
- Always use original spare parts.
- Repairs can be performed only by authorised staff people authorised by Unior d.d.
- Always disconnect tools not in use from the air supply.