

Avara kasnađı skme aleti

1670/2BI-US



Profiles







Product features

- malzeme: zel alet eliđi, sertleřtirilmiř ve temperlenmiř
- yzey bitirme: ISO 1456:2009 standardına gre krom kaplamalı
- ergonomik ađır hizmet tipi iki bileřenli sap
- Two configurations: one for 10/11/12t small-cog cassettes, one for 13/14t small-cog cassettes
- Ridges on the outside of the pins provide a secure grip on the casset.
- Access hole allows for a cassette lockring tool to fit.

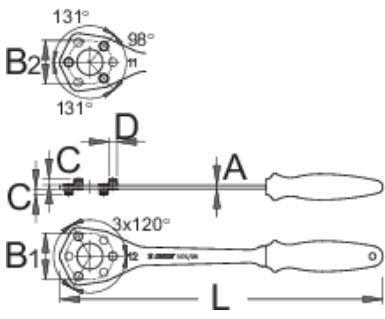
Aletin kullanımı:

- Modern replacement of the traditional chain whip
- Pins on the tool engage with the smallest sprocket on the cassette and hold it in place, while the opening in the middle allows for easy access to the cassette lockring.
- Version for 11- & 12-tooth sprockets has longer pins on the "12t" side. This makes it fully compatible with cassettes where two smallest sprockets have 10 and 12 teeth. For removal of the sprocket, where the smallest sprocket has 10t, the tool reaches over it and engages with the next 12t sprocket.



|  |  | L | D | A | C | B1 | B2 |  |
|--|---|-----|-----|---|-----|------|------|---|
| 624931 | 11/12 | 350 | 8,6 | 4 | 6,4 | 49,8 | 46 | 238 |
| 624967 | 13/14 | 350 | 8,6 | 4 | 6,4 | 53,1 | 57,7 | 238 |

* Ürünlerin resimleri semboliktir. Bütün boyutlar mm ve ağırlık gram cinsindedir.