

Cassette wrench

1670/2BI-US



Profielen







Product attributen

- materiaal: premium flex plus carbonstaal
- surface finish: chrome plated according to ISO 1456:2009
- ergonomic heavy duty double component handle
- Two configurations: one for 10/11/12t small-cog cassettes, one for 13/14t small-cog cassettes
- Ridges on the outside of the pins provide a secure grip on the cassette.
- Access hole allows for a cassette lockring tool to fit.

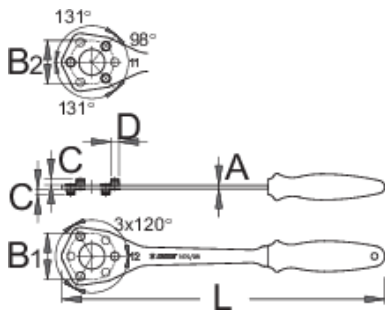
How to use the tool:

- Modern replacement of the traditional chain whip
- Pins on the tool engage with the smallest sprocket on the cassette and hold it in place, while the opening in the middle allows for easy access to the cassette lockring.
- Version for 11- & 12-tooth sprockets has longer pins on the "12t" side. This makes it fully compatible with cassettes where two smallest sprockets have 10 and 12 teeth. For removal of the sprocket, where the smallest sprocket has 10t, the tool reaches over it and engages with the next 12t sprocket.



		L	D	A	C	B1	B2	
624931	11/12	350	8,6	4	6,4	49,8	46	238
624967	13/14	350	8,6	4	6,4	53,1	57,7	238

* Afbeeldingen van producten zijn symbolisch. Alle afmetingen zijn in mm en gewicht in gram. Alle vermelde afmetingen kunnen variëren in tolerantie.