

# Ključ za lančanik

1670/2BI-US



## Profili

---







## Atributi proizvoda

- materijal: Premium Flex Plus ugljični čelik, ojačan i poboljšán
- površina kromirana ISO 1456:2009
- ergonomska, robusna, dvokomponentna drška
- Two configurations: one for 10/11/12t small-cog cassettes, one for 13/14t small-cog cassettes
- Ridges on the outside of the pins provide a secure grip on the casset.
- Access hole allows for a cassette lockring tool to fit.

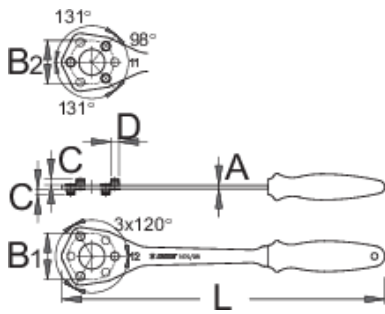
## Kako upotrijebiti alat:

- Modern replacement of the traditional chain whip
- Pins on the tool engage with the smallest sprocket on the cassette and hold it in place, while the opening in the middle allows for easy access to the cassette lockring.
- Version for 11- & 12-tooth sprockets has longer pins on the "12t" side. This makes it fully compatible with cassettes where two smallest sprockets have 10 and 12 teeth. For removal of the sprocket, where the smallest sprocket has 10t, the tool reaches over it and engages with the next 12t sprocket.



		L	D	A	C	B1	B2	
624931	11/12	350	8,6	4	6,4	49,8	46	238
624967	13/14	350	8,6	4	6,4	53,1	57,7	238

\* Slike proizvoda su simbolične. Sve dimenzije su u mm, masa je u g.