

# Pneumatische beitelhamer

1514



## Profielen



## Product attributen

- used for cutting sheet, bolts and removing welding slag, rivets, plaster and tiles
- with spring, quick change retainer as spare parts
- piston stroke length: 170 - 67mm, 225 - 92mm
- bore diameter 9,1mm
- stroke per minute: 170 - 3000, 225 - 2100
- air consumption 250 l/min
- air inlet 1/4"



## Voordelen:

- light and compact tool, used also in small rooms
- wide range of use
- change retainer

## Gebruik:

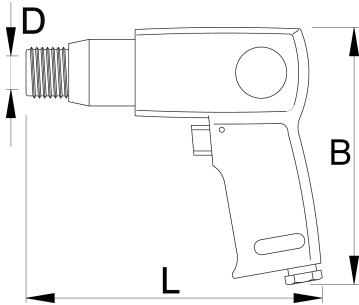
- car industry
- cutting of sheet metal and screws
- removal of welds
- working on walls, concrete, stones, bricks, steel, light metals



	L	B	D	
617714	170	150	19	1810
617715	225	150	19	2160

\* Afbeeldingen van producten zijn symbolisch. Alle afmetingen zijn in mm en gewicht in gram. Alle vermelde afmetingen kunnen variëren in tolerantie.

## Gebruik (Afbeeldingen)



## Foto (Afbeeldingen)



## Accessoires



Veer voor 1514



Snelwisselhouder voor 1514



Koudbeitel, plat-ovaal



Puntbeitel, 8-kantig



Snij- en lasbeitel



Plaatwerkbeitel



V-groef beitel



Voegbeitel



Koppeling, man



Koppeling, man



Koppeling, vrouw



Koppeling, vrouw



Pneumatische filterdrukregelaar en olieverniveelaar 3/8"



Pneumatische filterdrukregelaar en olieverniveelaar 1/2"



Spiraalslang

## Veiligheidstips



- The pressure in the tool during the operation has to be at least 6.2 bar for the tool to work properly.
- Regularly clean and dry the air filters and inlet air supply.
- Always use clean and dry air with the correct mixture of oil, for maximum tool life.
- Check the joints and ensure that the tubes and other equipment are not



- Always disconnect tools not in use from the air supply.

damaged before use.

- All tools should be gently oiled prior to being stored.
- Always store pneumatic tools in dry places away from water.
- Always use original spare parts.
- Repairs can be performed only by authorised staff people authorised by Unior d.d.